

CAD FILE:

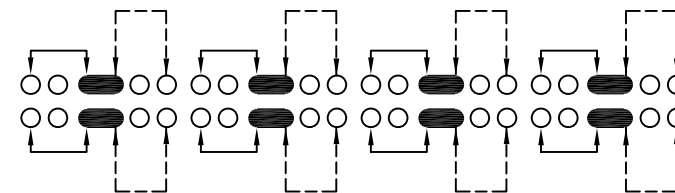

**SCHEMATIC (NON-SPECIFIED)**

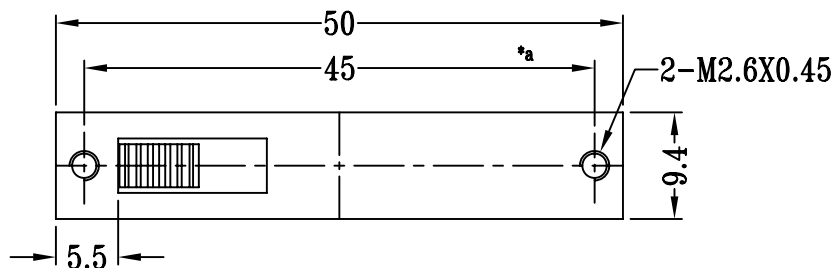
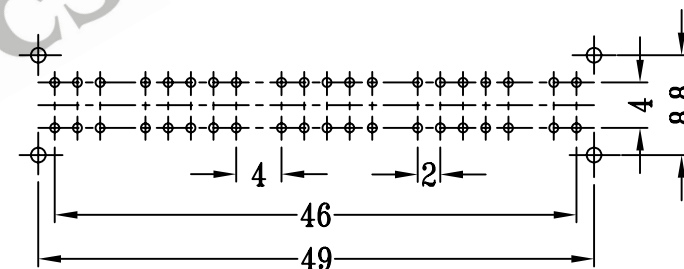
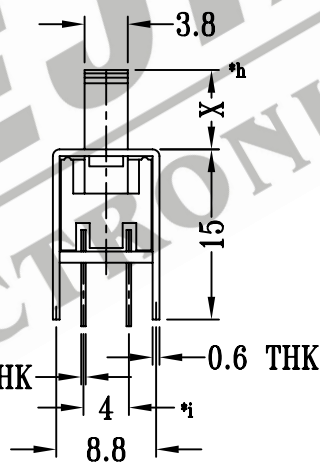
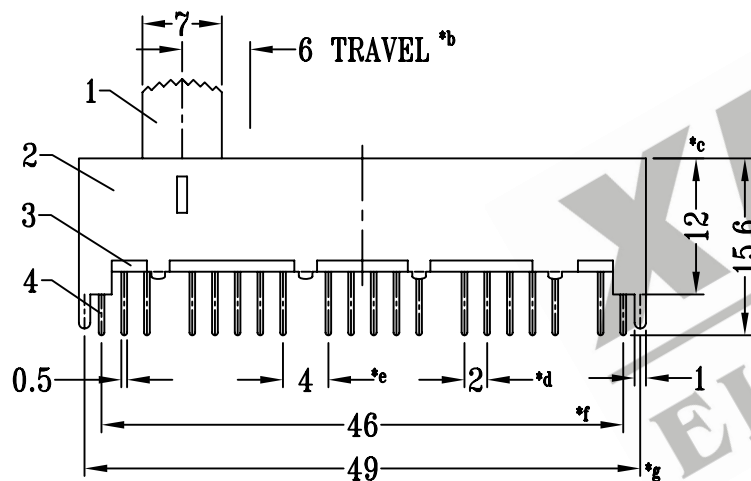

**P.C.B LAYOUT**

注:带"\*"表示关键尺寸(9个)

NO.	PART NAME	MATERIAL	Q'TY	FINISHING	TOLERANCE UNLESS SPECIFIED	SHENZHEN XIEJIA ELECTRONICS CO.,LTD.				
8						ISSUE	DATE	DESCRIPTIONS		APPD.
7	CONTACT CLIP	PBS STRIP	8	Ag PLATED	WITHIN: 1.5±0.1mm					
6	STEEL BALL	STEEL	2	NATURAL	OVER : 1.5±0.2mm	MODEL: SS-82L02		SCALE: 3:2	DWN. ZHOUYU	2002-12-12
5	SPRING	STEEL WIRE	1	TEMPER					CHK'D FANGYING	2002-12-12
4	TERMINAL	BRASS STRIP	40	Ag PLATED OVER Ni PLATED					APPD. KANGXINAN	2002-12-12
3	BASE	PHENOLIC RESIN	1	NATURAL						
2	FRAME	STEEL STRIP	1	Ni PLATED						
1	KNOB	POM	1	BLACK						
					ALL MATERIALS MUST BE COMPLIANT TO ROHS					